 <p style="text-align: center;">INDUSTRY TECHNICAL NOTE COLD FORMED STEEL CONSTRUCTION</p>	3
	APRIL 2000

TRACK WITHIN A TRACK DEFLECTION ASSEMBLY

INTRODUCTION

Since the popular use of steel studs for framing full height walls, there has been a recognition that the top of the wall needs to allow for deflection of the floor or roof assembly above when subjected to an applied vertical live load. The allowance for deflection is essential for interior non-load bearing applications.

It has been common practice to utilize a track nested into another track with no attachment of the nested inner track to the outside track. Wall sheathing can be attached to the nested track providing the legs of the inside track are of sufficient length so the screw attachment does not interfere with the vertical movement of the deflection assembly. The track within a track allows the stud at the top of the wall to be attached to the inside track to provide a more uniform load transfer to the outside deflection track flange, and to stabilize the studs against rotation.

OBSERVATIONS

With the nested track attached to the stud flange (see Figure 1) the load transfer is uniformly distributed along the inner track to the leg of the outer track. Using the basics of strength of materials, the thickness of the outer deflection track can be determined.

It is recommended that the steel used for the deflection track (outer track) have good ductility

characteristics, (tensile strength to yield point ratio not less than 1.08 and total elongation not less than 10 percent in a two-inch gage length). Good ductility characteristics reduce the possibility of micro cracking during the roll-forming process and provides inelastic reserve.

Satisfactory performance is based on the following:

1. Each stud flange is stabilized to resist rotation of the stud by attaching the stud flange to the leg of the nested (inner) track.
2. The inner track has sufficient stiffness to provide a uniform distribution of load to the deflection (outer) track.

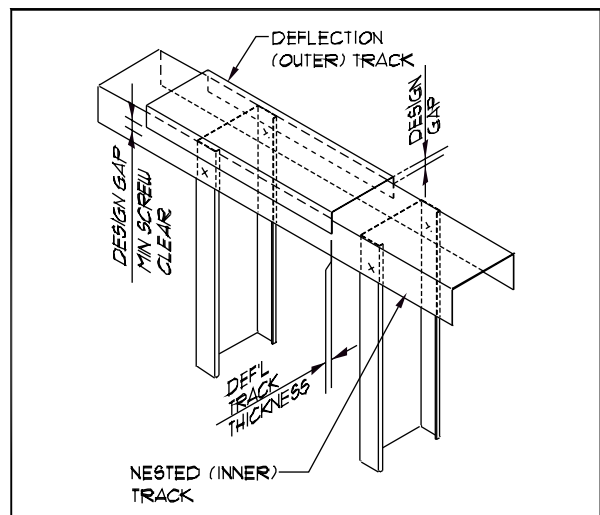

FIGURE 1

DEFLECTION TRACK THICKNESS DETERMINATION

Deflection track (outer track) thickness can be determined based on the principals of strength of materials. The equation for determining the required thickness is:

$$t = \sqrt{\frac{0.833 \cdot P \cdot e}{F_y}}$$

where:

- t = required design thickness, in inches.
- P = the maximum reaction at the top of the wall, in lbs/ft. NOTE: The equation includes the 0.75 reduction factor for wind or earthquake loads per A5.1.3 of the AISI Specification. (Check local building code for application of reduction factor).
- e = distance between the track web and the point of application of the reaction P, in inches (design gap times 1.5).
- F_y = minimum steel yield stress, in psi.

Design curves can be developed for a given non-load bearing (non-axial load) wall height, lateral load (typically 5psf for interior walls), design gap (gap between the inner and outer track webs), and the minimum yield stress of the material to be used, either 33 ksi or 50 ksi (50 ksi is noted on the curve). A series of such curves are given in Figures 2 through 5. The required design thickness of the deflection track (outer track) can then be determined from the figure.

Design load = 15 psf
 Design gap = 0.5"
 Wall height = 13'-6"
 Min. Steel Yield Stress = 33 ksi

From Figure 2 the deflection track design thickness of t = .0451" (18ga.) can be used.

NOTE: Maximum allowable wall height = 19.0 ft.

Thickness - Steel Components

Minimum Thickness ¹ (mils)	Design Thickness (in)	Reference On Gauge No.
18	0.0188	25
27	0.0283	22
33	0.0346	20
43	0.0451	18
54	0.0566	16
68	0.0713	14
97	0.1017	12

¹ Minimum Thickness represents 95% of the design thickness and is the minimum acceptable thickness delivered to the job site based on Section A3.4 of the 1996 AISI Specification.

It is recommended that the depth of the deflection track (outer track) flange be equal to the design gap plus 1 inch for one story buildings, and equal to 2 times the design gap plus 1 inch for all other applications to provide engagement of the nested (inner) track into the deflection track. The longer track leg for multiple story buildings, allows for the floor system supporting the stud wall to deflect while still maintaining engagement of the stud in the deflection track.

The depth of the nested (inner) track flange that engages the wall stud should be equal to the design gap plus 1-½ inches for one story buildings, and equal to 2 times the design gap plus 1-½ inches for all other applications. The additional inner track flange length to be installed allows the screw connecting the track to the stud so the screw does not interfere with the vertical movement of the deflection assembly

NOTE: The minimum uncoated delivered thickness of the cold-formed product can be equal to 95 percent of the design thickness per the 1996 AISI "Specification for The Design of Cold-Formed Steel Structural Members", Section A3.4.

The technical data provided in this publication should not constitute any representation or warranty expressed or implied, on the part of SSMA or any individual that the information is suitable for any general or specific application. Any individual or entity making use of the information contained herein assumes all risk and liability arising or resulting from such use.

^{a,b,c}
DESIGN CHART FOR DEFLECTION (OUTER) TRACK

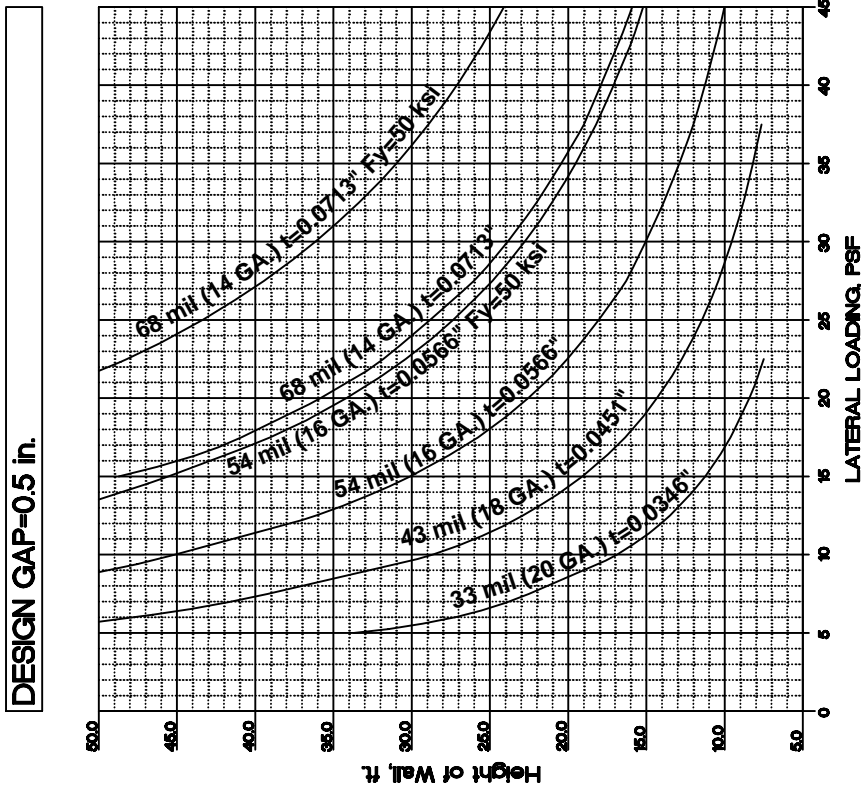

FIGURE 2

- Notes:
- a. Fy=33 ksi unless noted otherwise.
 - b. t=Design thickness.
 - c. Lateral load has been modified for duration of load (0.75) per A5.13 of the AISI Specification. No further reduction allowed; increase lateral load where other load durations govern.

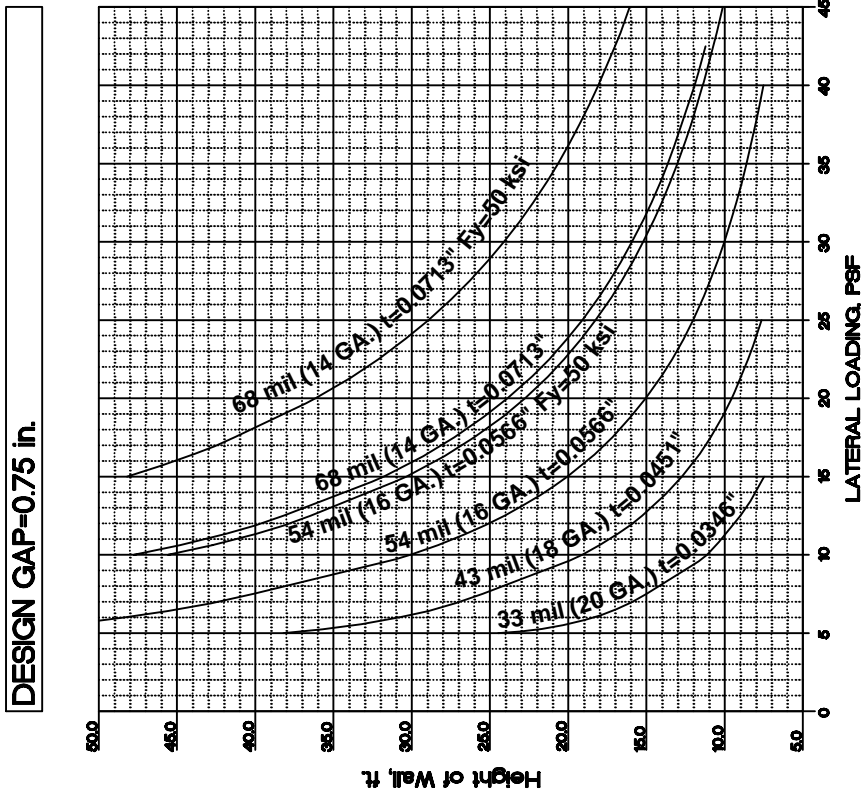

FIGURE 3



DESIGN CHART FOR DEFLECTION (OUTER) TRACK ^{a,b,c}

DESIGN GAP-1.0 in.

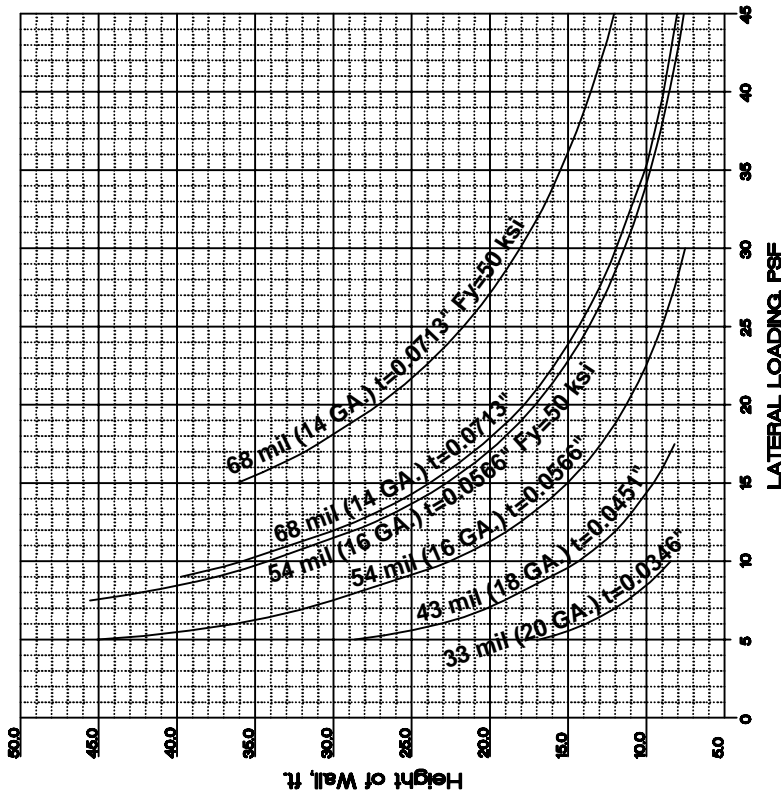

FIGURE 4

- Notes:
- a. $F_y=33$ ksi unless noted otherwise.
 - b. t -Design thickness.
 - c. Lateral load has been modified for duration of load (0.75) per A5.1.3 of the AISI Specification. No further reduction allowed; increase lateral load where other load durations govern.

DESIGN GAP-1.5 in.

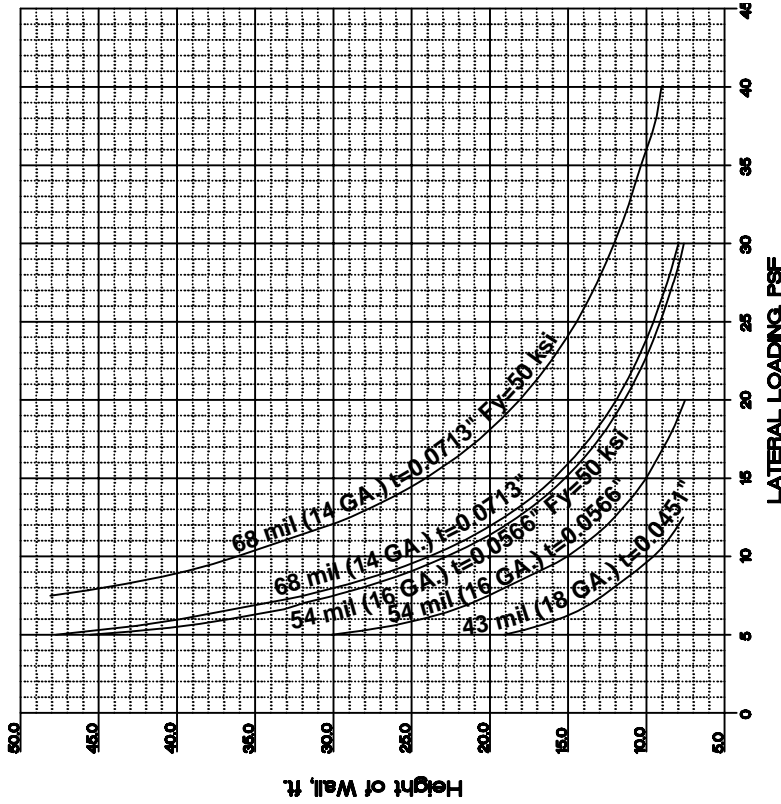

FIGURE 5